

Variable Displacement Vane Pump

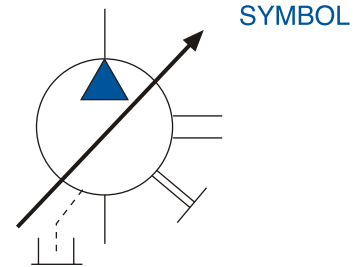

Model Code

VCM - SM - 30 - B - 20

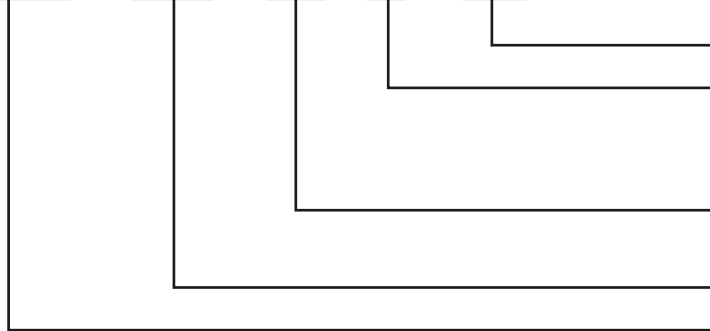

Design No.
 Pressure range
 A:35kgf/cm² C:105 kgf/cm²
 B:70kgf/cm² D:140 kgf/cm²
 Displacement at 1800 rpm
 30L,40L 30L, 40L
 Series No.
 Vane Pump Series

FEATURE:

1. High efficiency, high-pressure, operation.
2. Extremely low vibration and noise level.
3. Instant and sharp cut-off characteristics.
4. Sturdy structure for high efficiency and long service life.
5. Easy adjustment in handling and maintenance.

Technical Data

MODEL	Delivery at no load L/min		Pressure Adj Range kgf/cm ²	Shaft Speed rpm		Max Pressure kgf/cm ²	Weight Kg Flange
	1800rpm	1500rpm		Max	Min		
SM-30A	30	25	15-35	1800	800	35	9.7
SM-30B			20-70			70	9.7
SM-30C			50-105			105	9.7
SM-30D			70-140			140	9.7
SM-40A	40	35	15-35	1800	800	35	9.7
SM-40B			20-70			70	9.7

Variable Displacement Vane Pump

Performance Curve

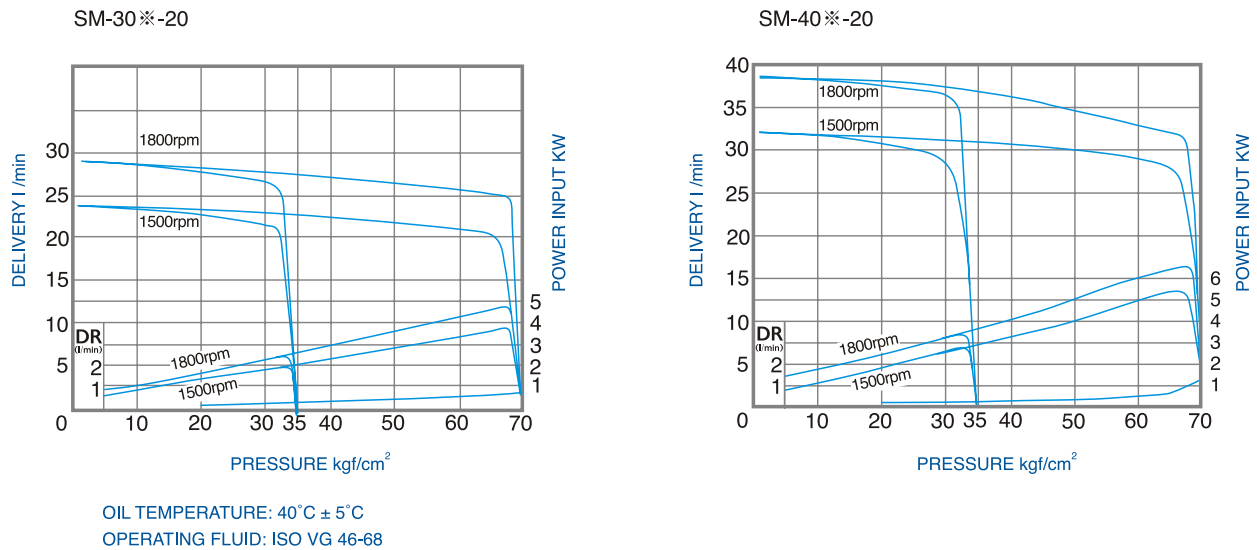

● VCM-SM

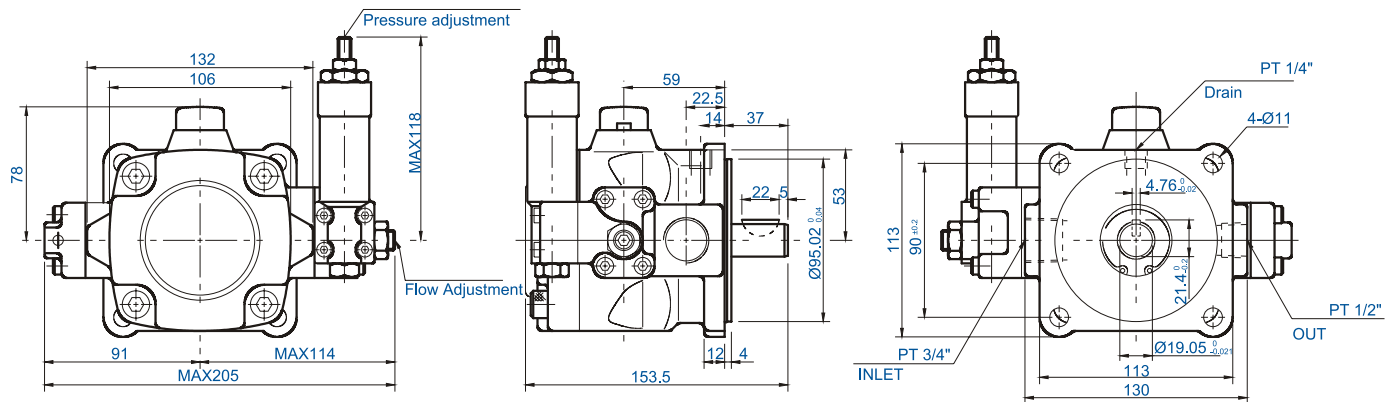

Handling

1. The rotation of VCM-SM pump is clockwise when viewed from the shaft end.
2. The drain pipe is directly connected to the oil tank and the position must be below the level of oil.
3. Keep the suction pressure within -0.3 bar at the suction port.
4. Pressure adjusting screw is turned clockwise to increase pressure and Counterclockwise to decrease pressure.
5. Flow adjusting screw is turned clockwise to increase flow and counterclockwise to decrease flow.
6. For proper alignment of pump and electric motor shaft, the eccentricity between them must be kept within 0.05mm and the eccentric angle error between them must be kept within 1°.
7. When pressure is under 70 bar the viscosity of oil must be within 30-50 cSt, when pressure is over 70 bar the viscosity of oil must be within 50-70 cSt, at the temperature of 40 °C.
8. When first time operation, the pump should be at no-load state-on delivery side and be repeated on and off the electric motor a number of times to make sure the air have been bled out of the system.